

(19) **United States**

(12) **Patent Application Publication** (10) **Pub. No.: US 2003/0030479 A1**

**Holdenried et al.**

(43) **Pub. Date: Feb. 13, 2003**

(54) **LOGARITHMIC AMPLIFIER**

**Publication Classification**

(75) Inventors: **Christopher D. Holdenried**, Calgary (CA); **James W. Haslett**, Calgary (CA); **John G. McRory**, Calgary (CA); **Robert J. Davies**, Calgary (CA)

(51) **Int. Cl.<sup>7</sup>** ..... **G06G 7/24**  
 (52) **U.S. Cl.** ..... **327/350**

Correspondence Address:

**CHRISTENSEN, O'CONNOR, JOHNSON, KINDNESS, PLLC**  
**1420 FIFTH AVENUE**  
**SUITE 2800**  
**SEATTLE, WA 98101-2347 (US)**

(57) **ABSTRACT**

A parallel-summation logarithmic amplifier is described that uses a novel topology of cascaded and parallel amplifiers to achieve extremely high bandwidth. Included in the topology is a unique delay matching scheme for logarithmic amplifiers that is amenable to fabrication in integrated circuit form. The result is flat group delay over broad frequency ranges and different power levels. The resulting log amplifier is suitable for radar applications and for use in high data rate fiber-optic networks. Also described is a unique design process that yields a set of amplifier gains that closely approximate a logarithm. Also described is the novel idea of using a parallel feedback amplifier (PFA) in piecewise-approximate logarithmic amplifiers. This innovation allows for the design of broadband amplifiers with significantly different gains and similar phase characteristics, which is extremely useful when designing high-frequency logarithmic amplifiers.

(73) Assignee: **Telecommunications Research Laboratories.**

(21) Appl. No.: **10/156,731**

(22) Filed: **May 24, 2002**

**Related U.S. Application Data**

(60) Provisional application No. 60/304,475, filed on Jul. 10, 2001.

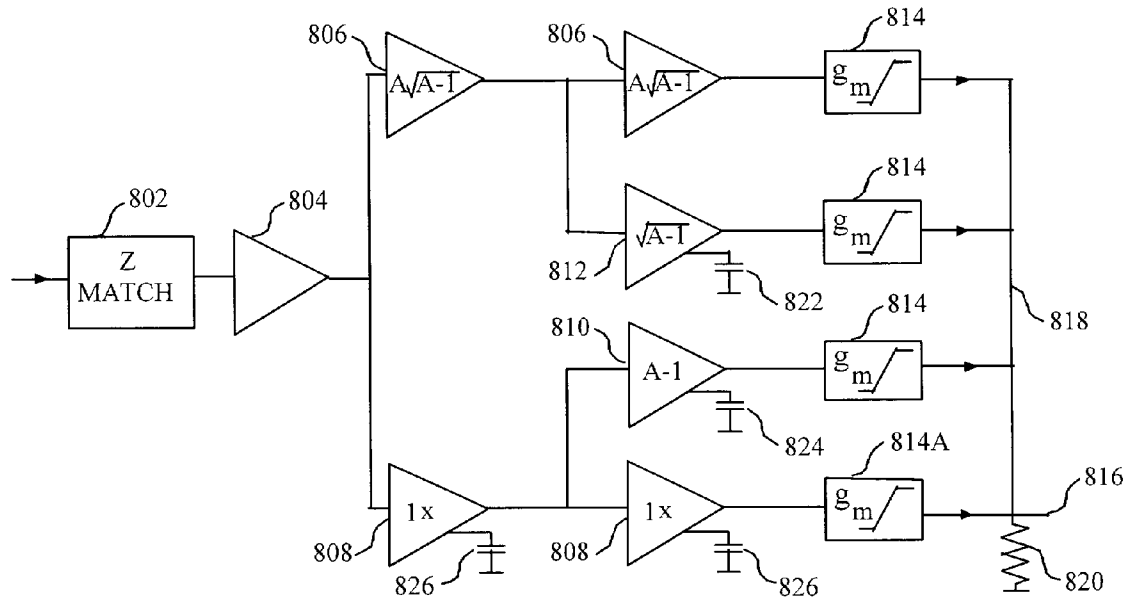

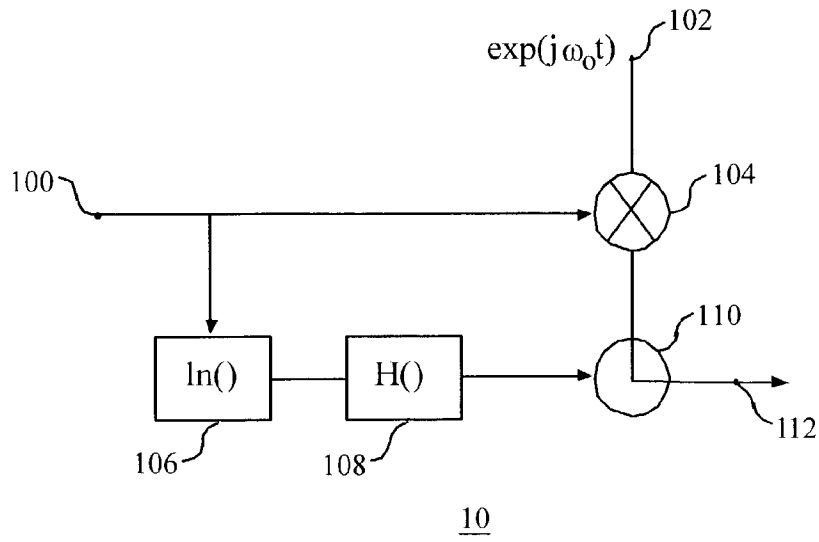

FIG. 1 PRIOR ART

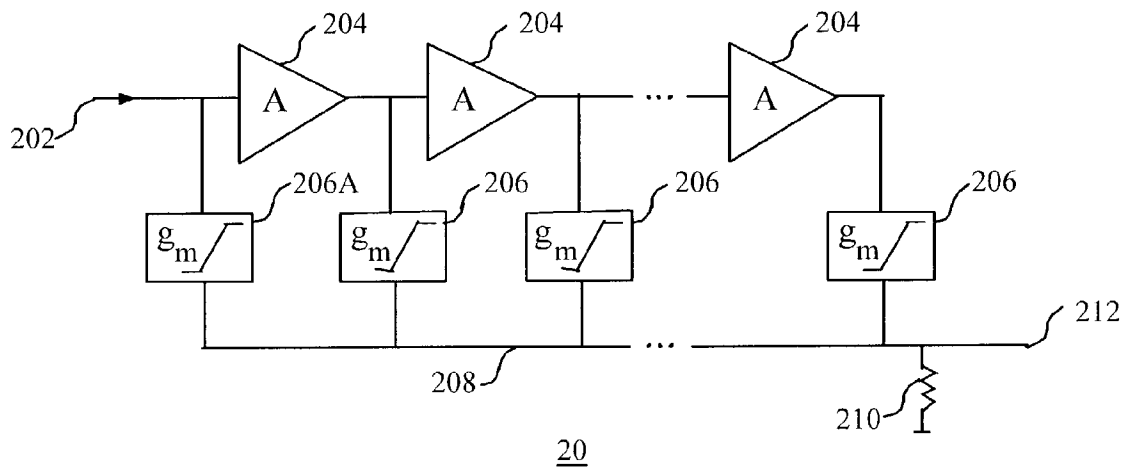
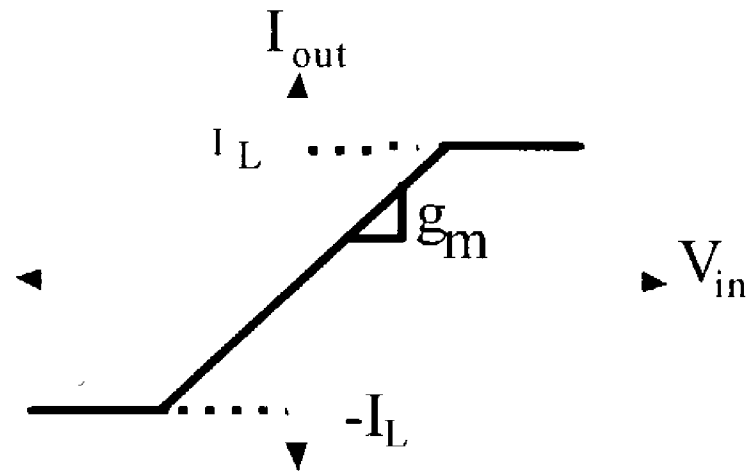
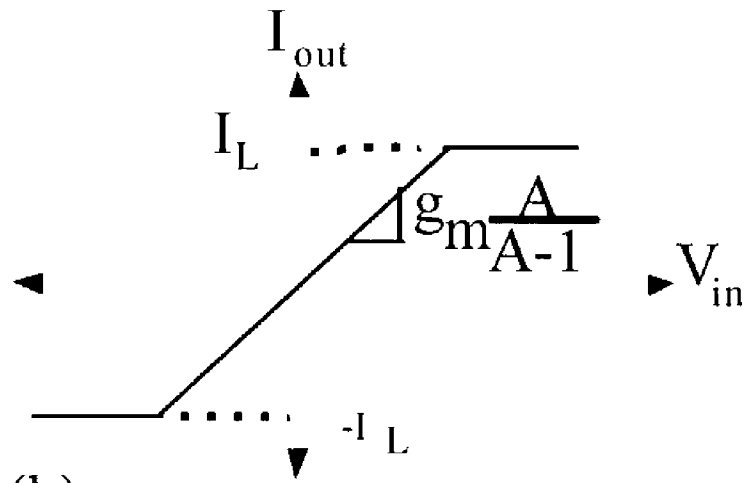

FIG. 2 PRIOR ART



(a)



(b)

FIG. 3

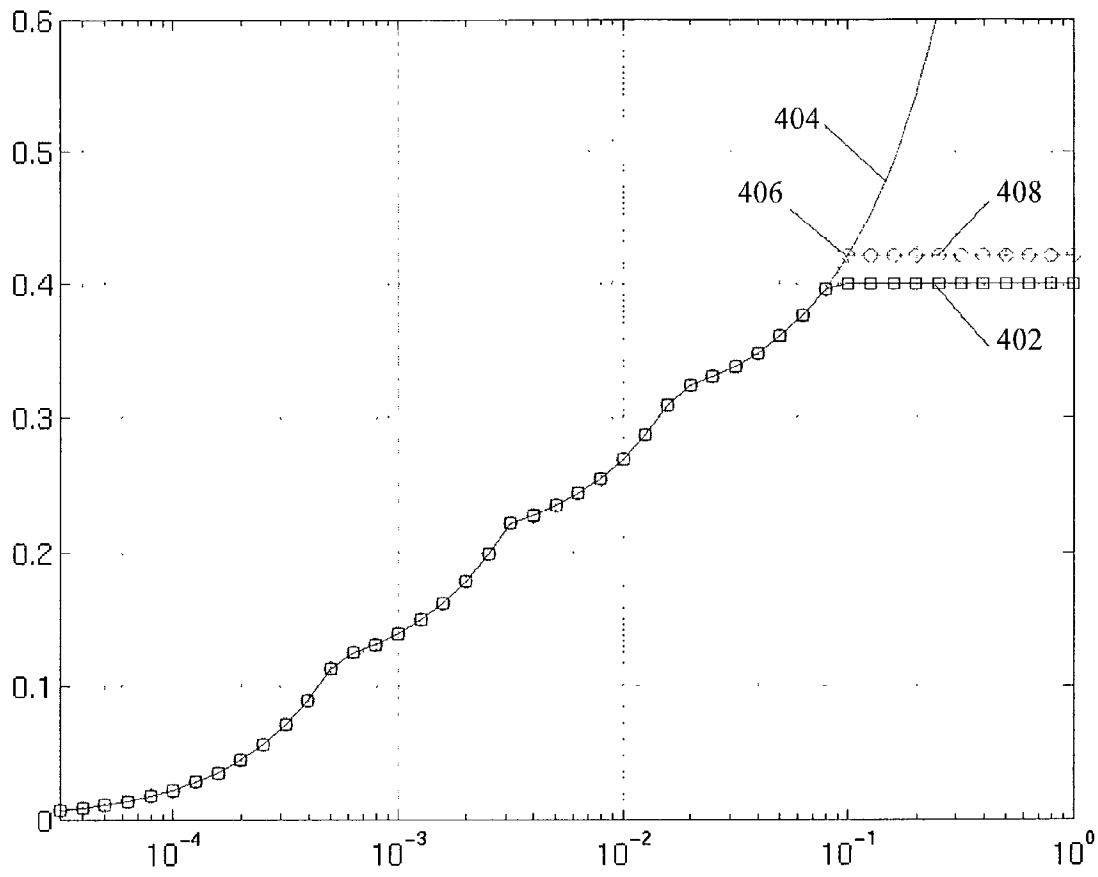

FIG. 4

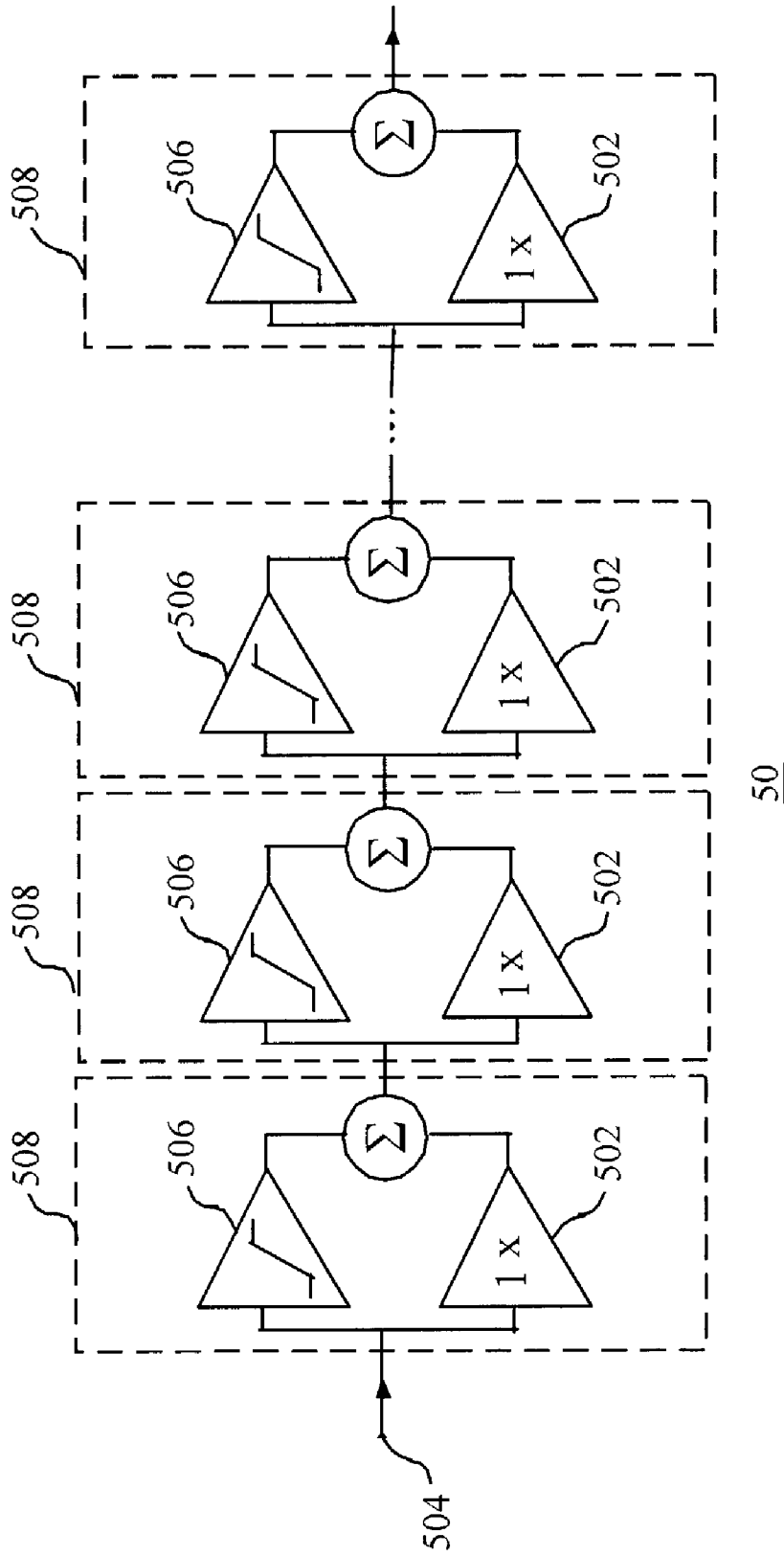

FIG. 5

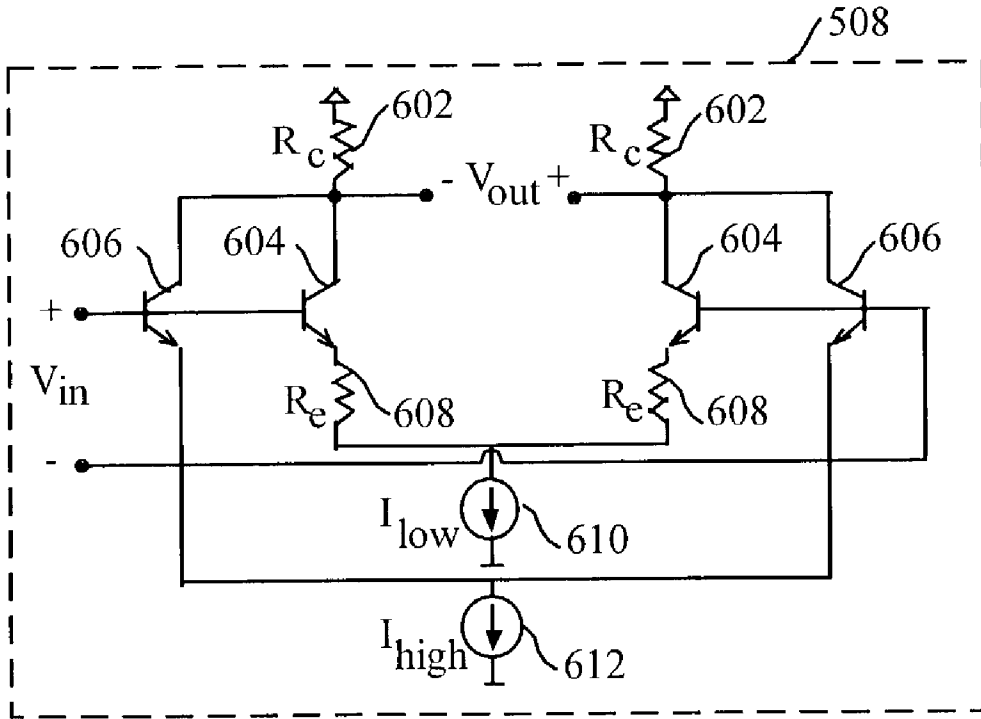

FIG. 6

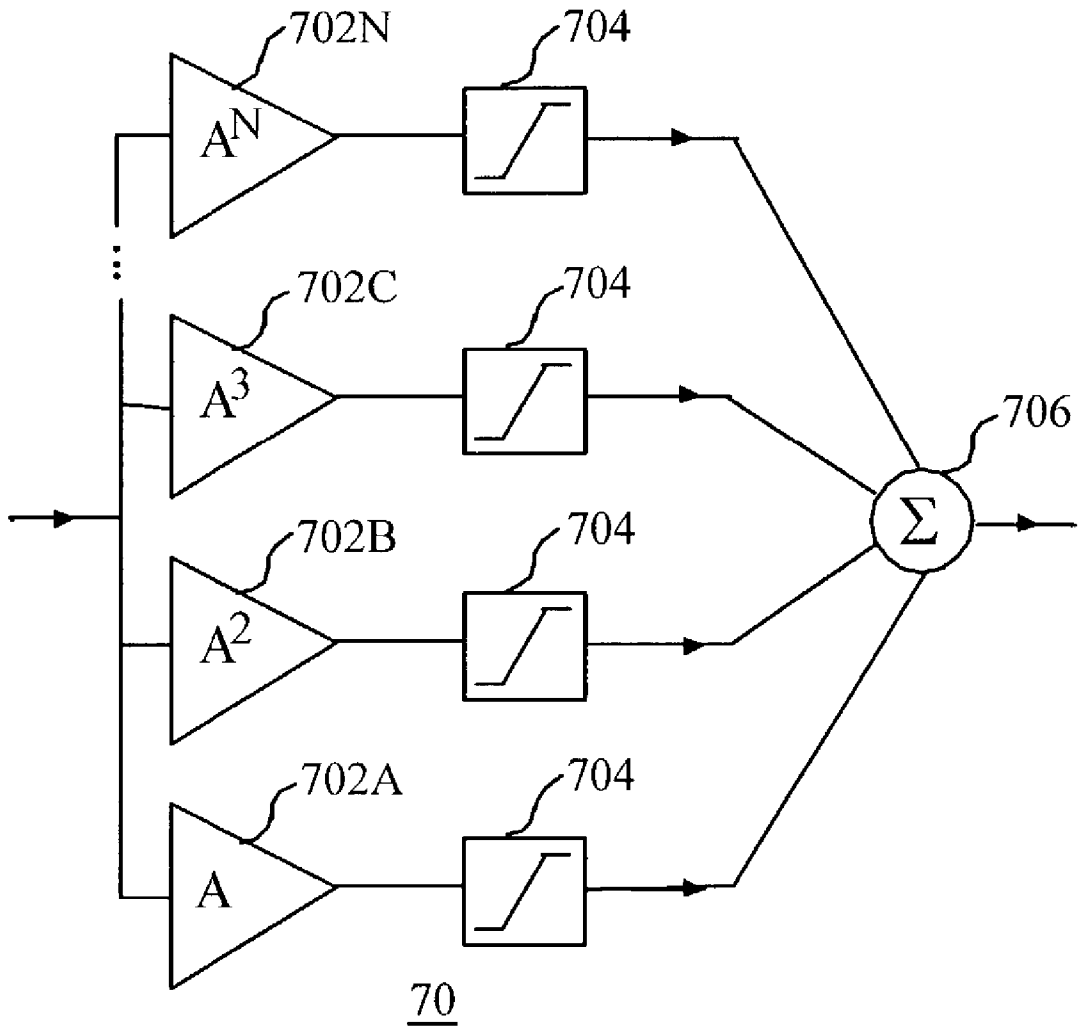
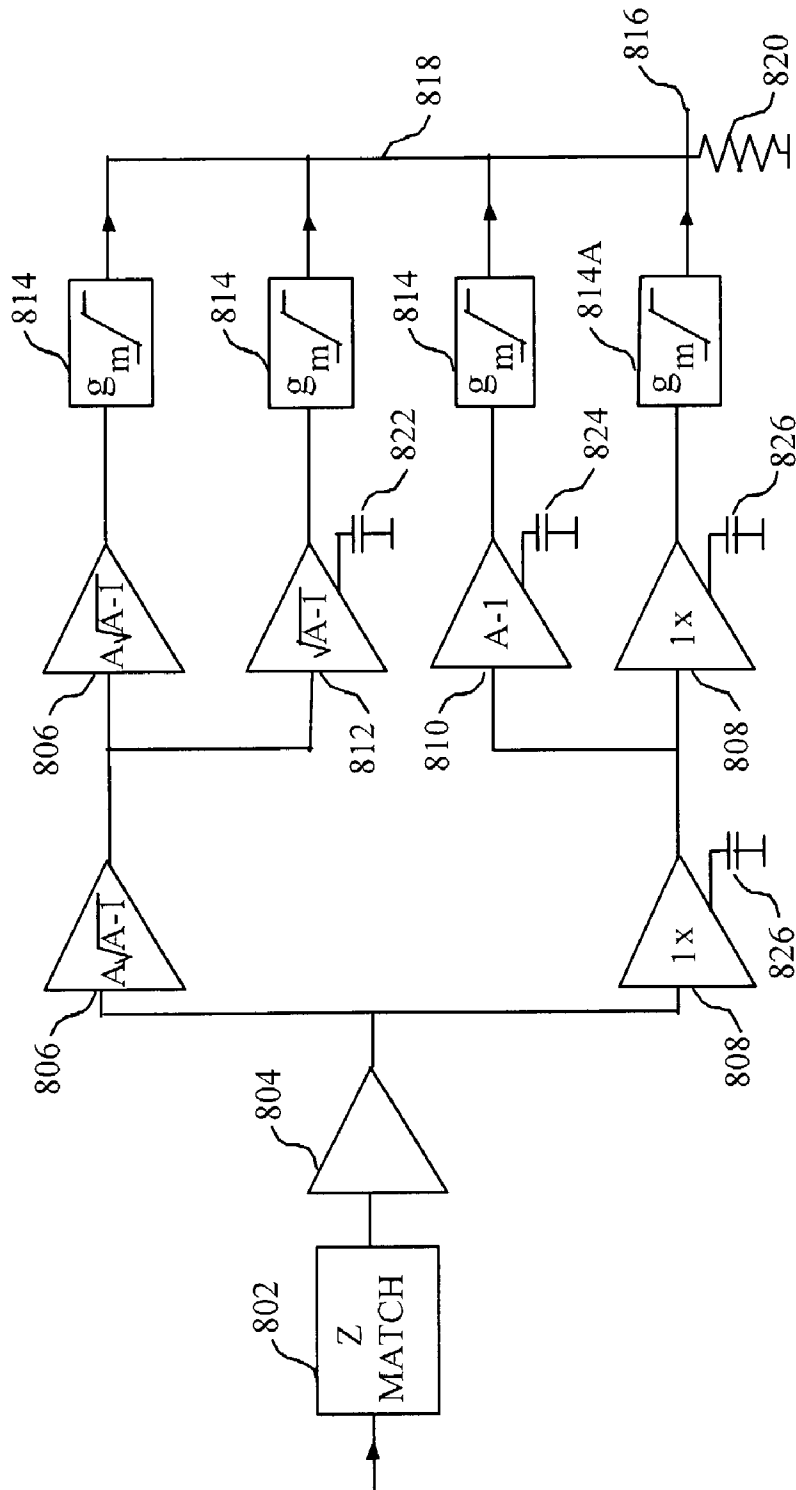

FIG. 7



80

FIG. 8



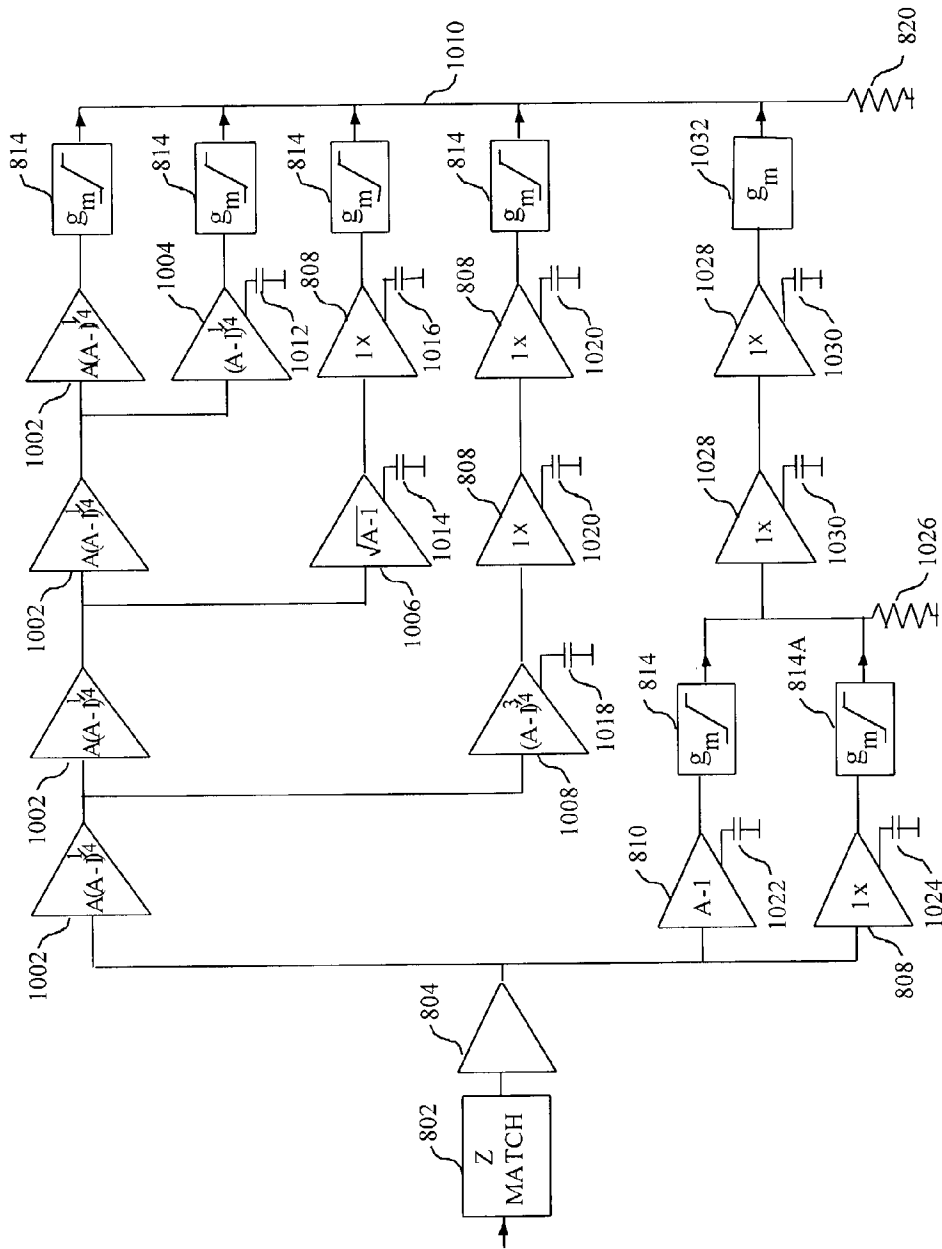

FIG. 10

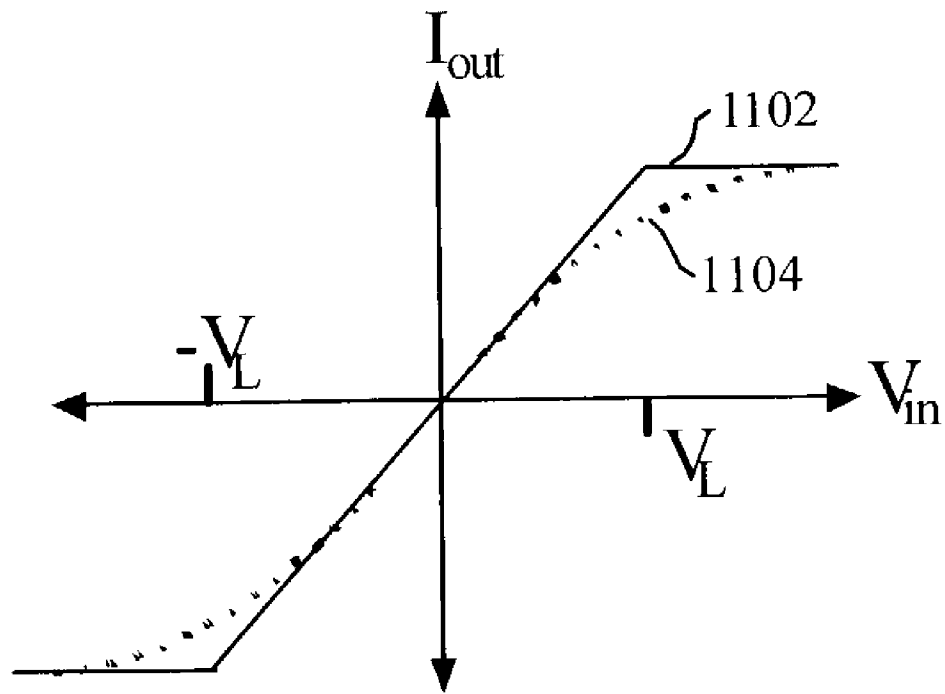

FIG. 11

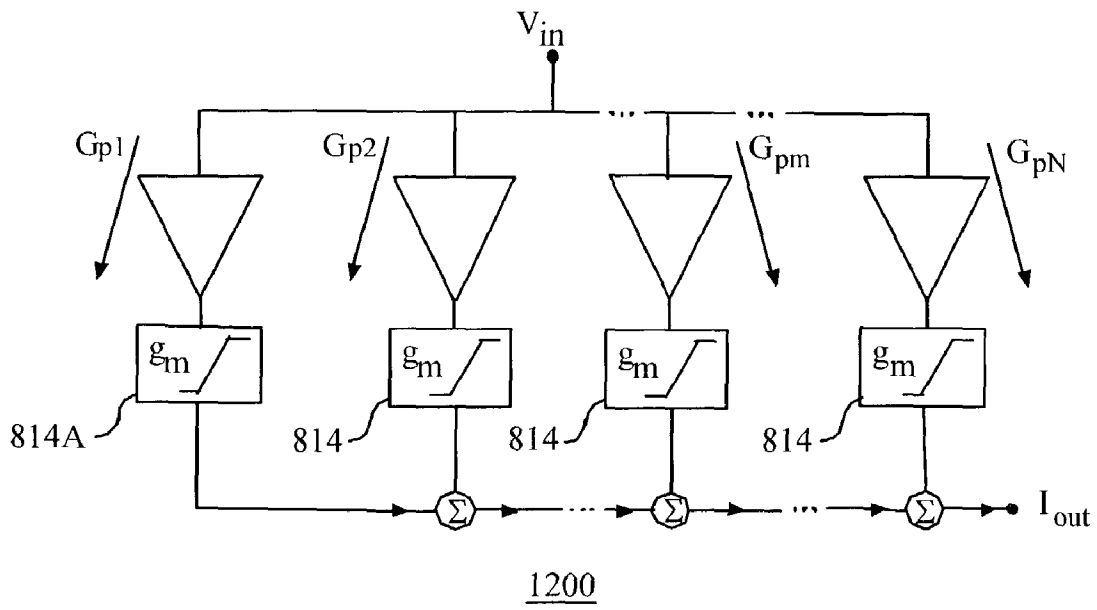

FIG. 12

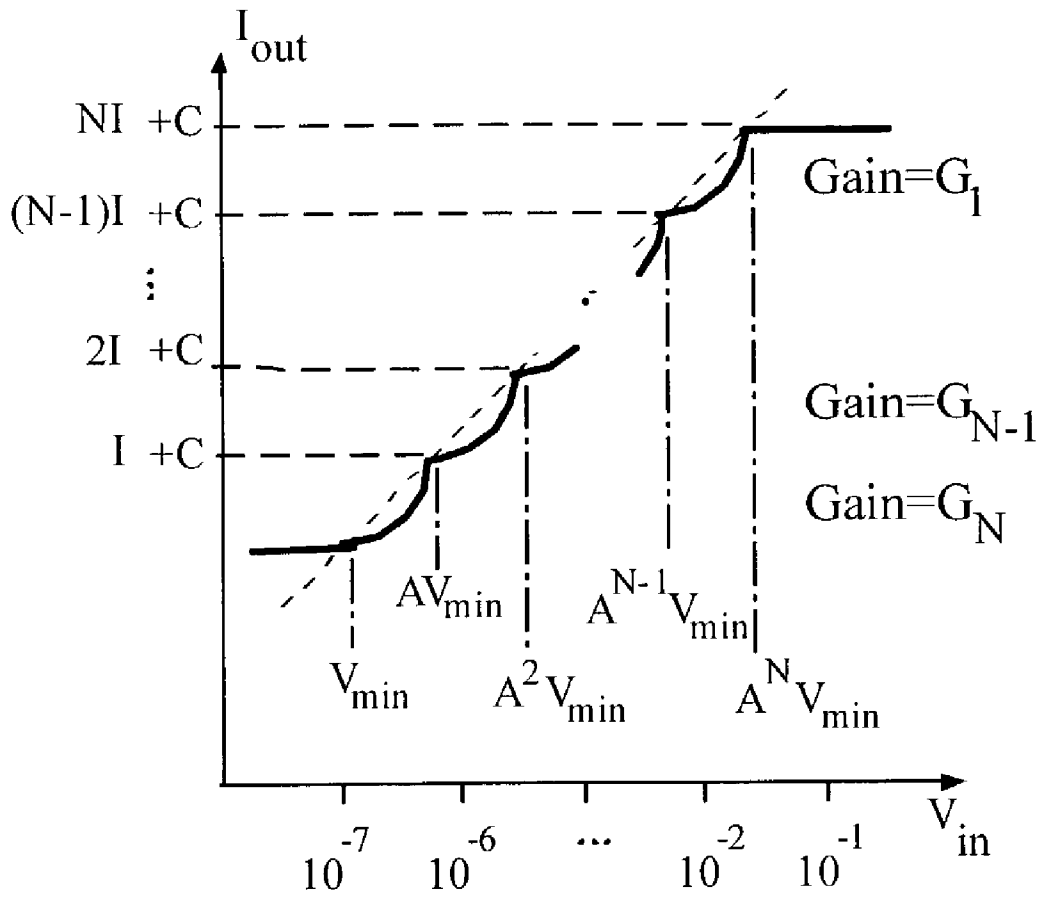
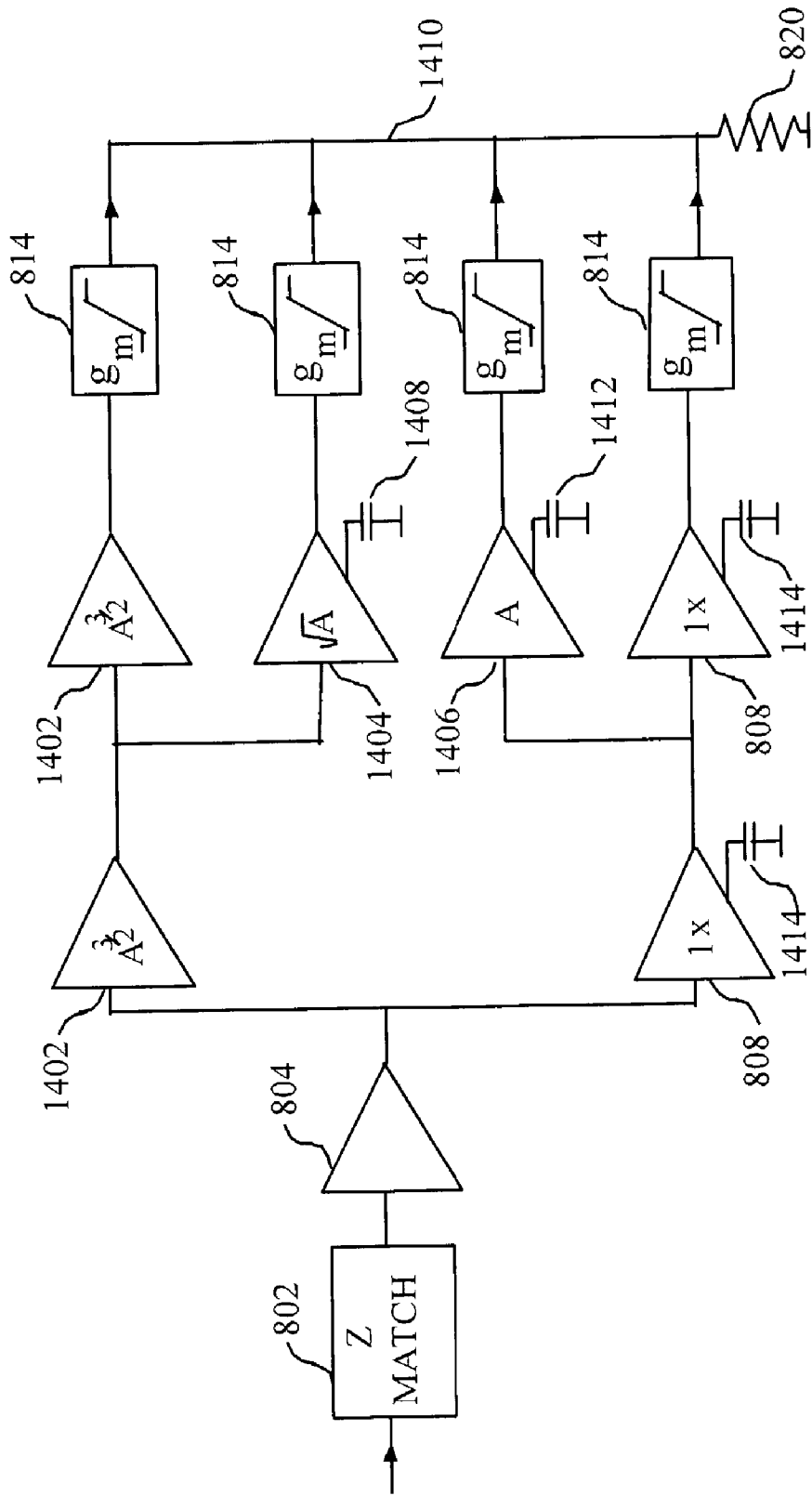

FIG. 13



1400

FIG. 14



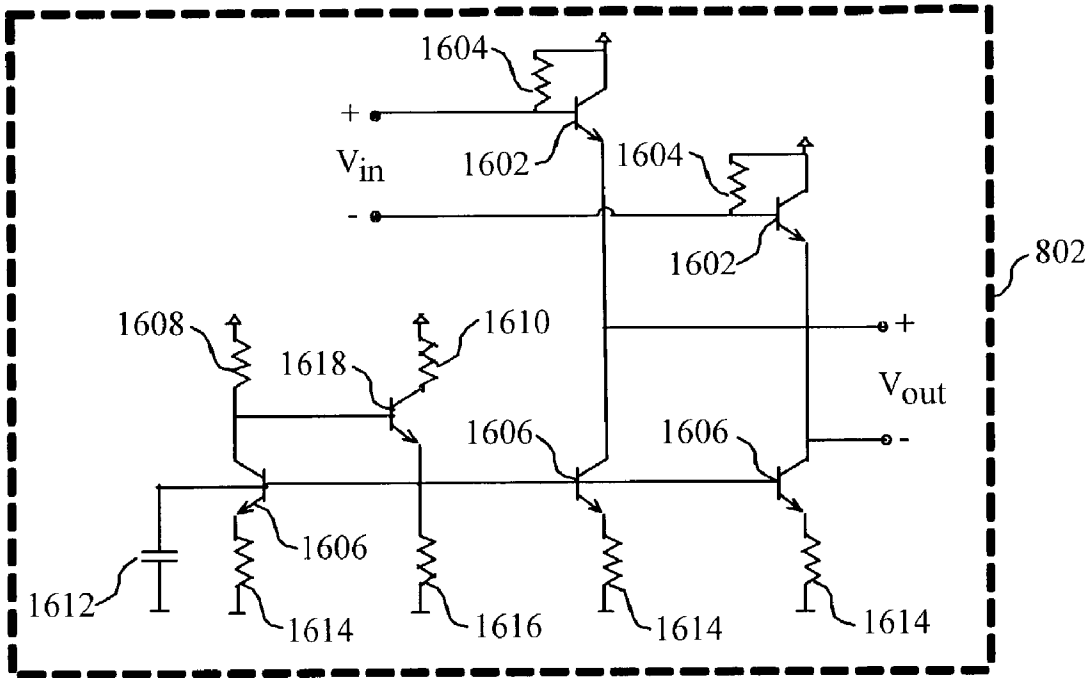
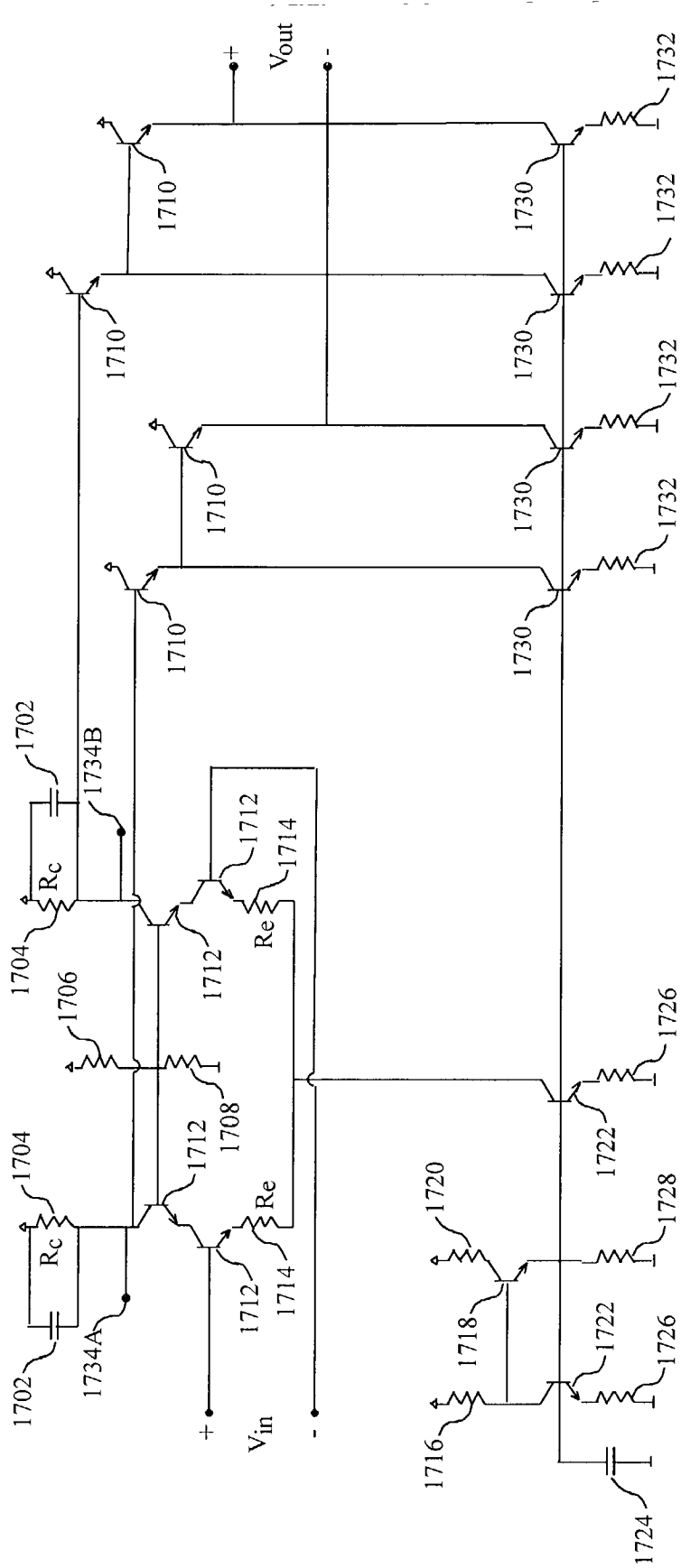
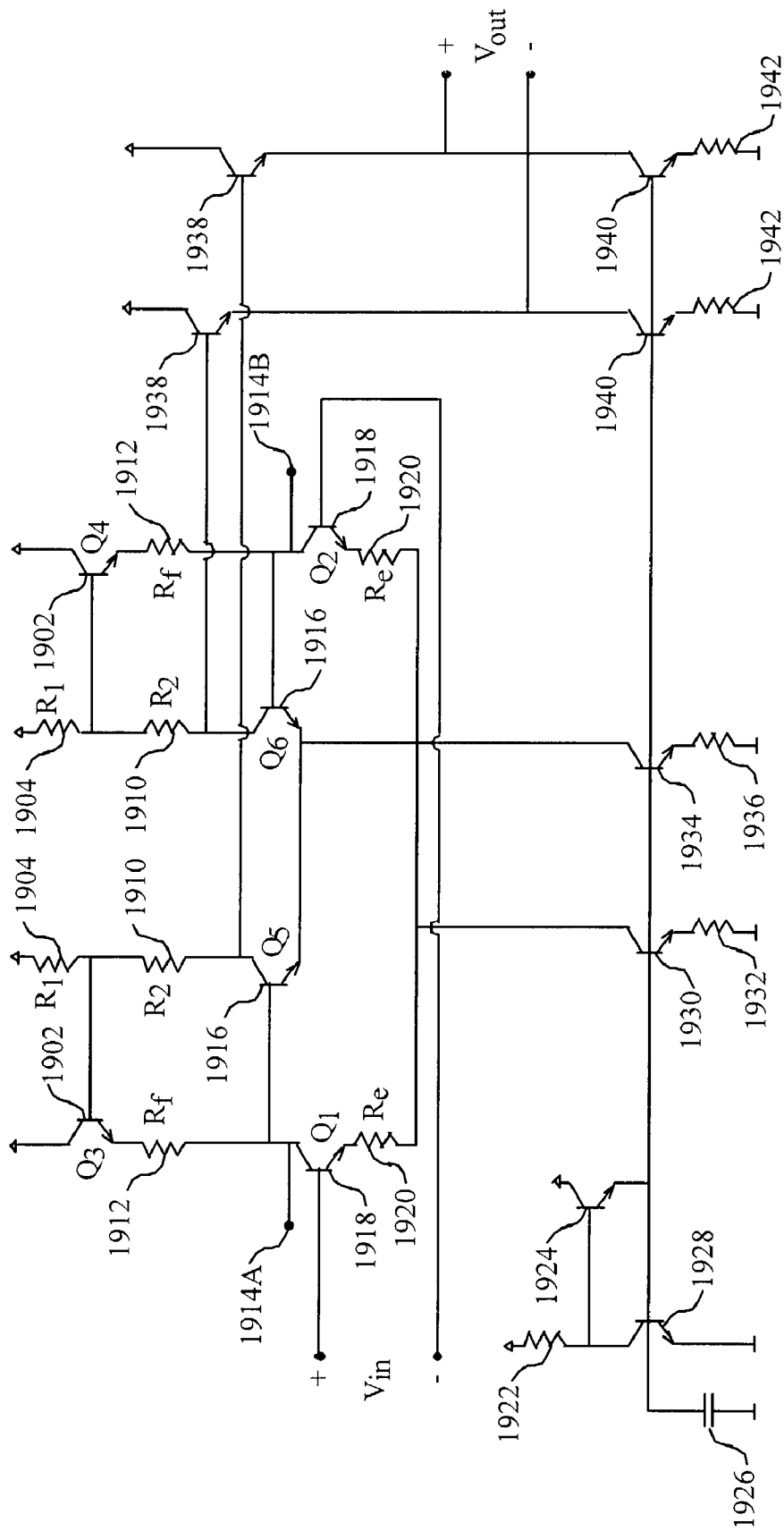

FIG. 16



1700  
FIG. 17





1900  
FIG. 19

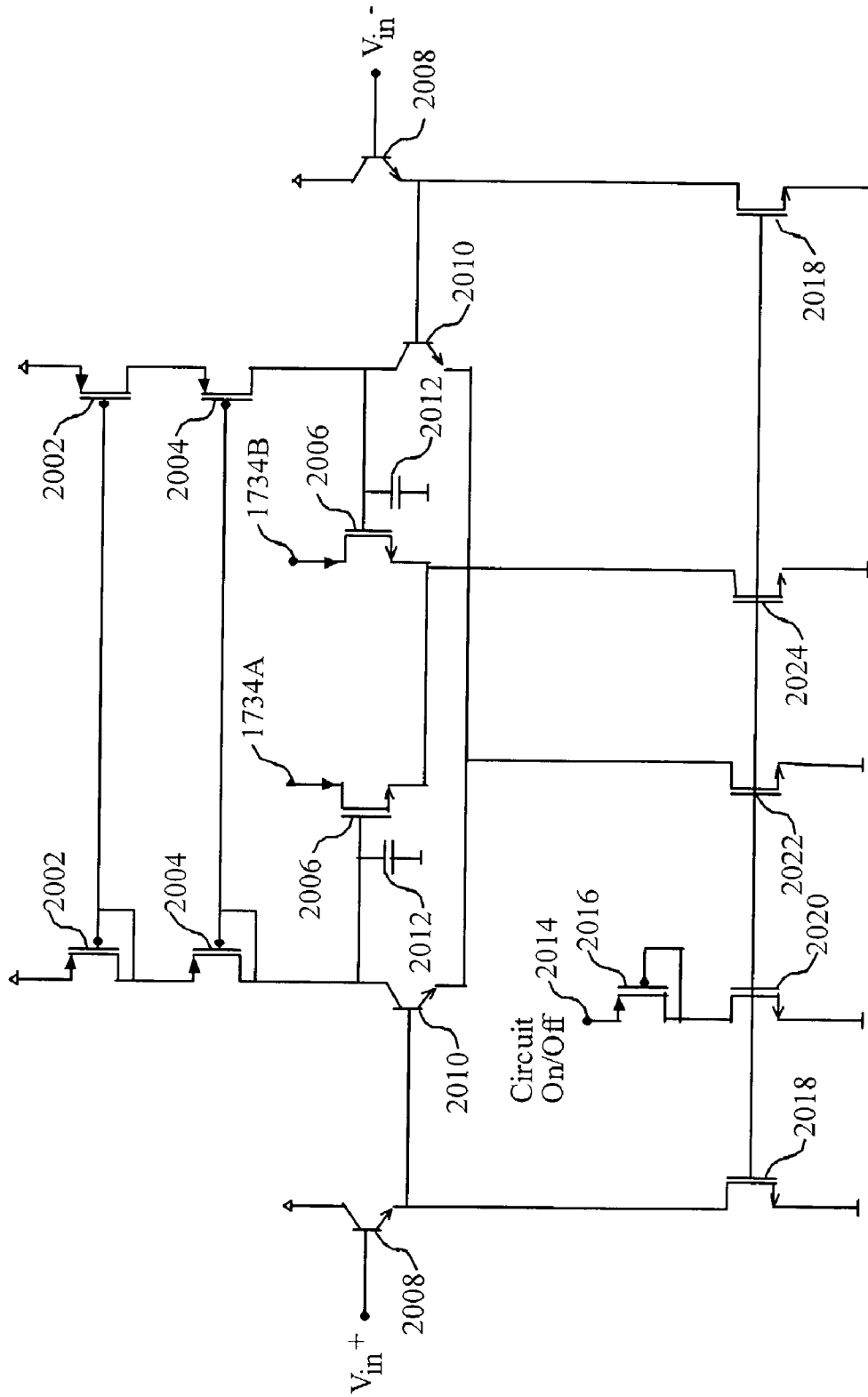

2000  
FIG. 20

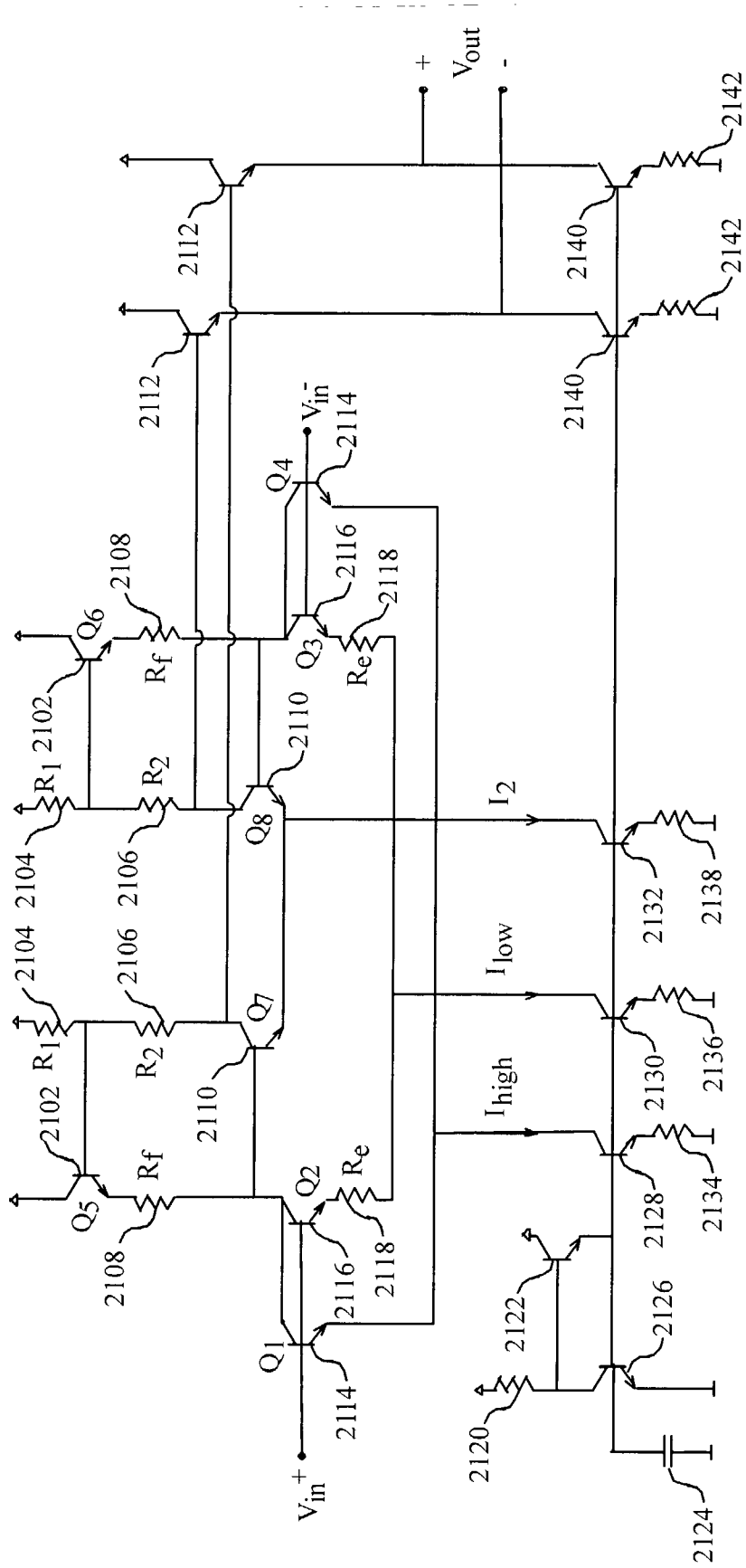

2100  
FIG. 21

## LOGARITHMIC AMPLIFIER

### CROSS-REFERENCE TO RELATED APPLICATION

[0001] This application claims the benefit of the filing date of U.S. Provisional Application No. 60/304,475 filed Jul. 10, 2001.

### BACKGROUND OF THE INVENTION

[0002] A logarithmic amplifier is a device that provides an output signal that will increment by a fixed amount each time the input signal increases by some factor. For example, a log amplifier may be designed to increment its output signal in response to a tripling or quadrupling of the input signal.

[0003] Early developments in logarithmic amplifiers came from the need to create a form of automatic gain control with high dynamic range in receivers for radar and electronic warfare. In these applications, the received signal power can vary by many orders of magnitude due to obstructions and reflections in the transmitting path. Logarithmic amplifiers are used to compress this large signal range into a smaller range that is more easily monitored on an electronic display or more easily captured with an analog-to-digital converter. Furthermore, a log amplifier may be used wherever the need for logarithmic arithmetic arises in instrumentation and signal processing in general.

[0004] Logarithmic amplifiers may also be used in fiber-optic receivers for gain control. The detected power in a fiber-optic receiver can vary due to bias point drift in both the transmitting laser and the receiver photodiode. Logarithmic amplifiers have been used to compress the high range of power levels provided by the photodiode. The advantage is to ease the task of the decision circuitry within the receiver and to protect it from optical overload.

[0005] Logarithmic converters may also be used in optical transmitters to aid in the task of performing single-sideband modulation of optical signals. An optical modulation system 10 that uses a logarithmic converter is shown in FIG. 1. An electrical information signal 100 is input to an optical amplitude modulator 104, and so the information signal amplitude-modulates the optical signal 102. As well, the signal is input to a logarithmic converter 106 serially coupled to a Hilbert transformer 108. Using an optical phase modulator 110, the output of the Hilbert transformer is used to phase-modulate the output of the optical amplitude modulator. The output of the phase modulator is an optical single-sideband signal 112. This scheme is particularly suited to high-data rate, baseband digital signals. The modulator is further described in U.S. Pat. No. 5,949,926.

[0006] There are two general categories of logarithmic converters; single stage converters and piecewise-approximate converters. Single stage converters, such as those that exploit the exponential voltage-to-current relation of PN junctions in bipolar transistors and diodes, provide efficient logarithmic conversion in low frequency applications. However, the present invention is concerned with high frequency operation and so only converters providing a piecewise-approximation to a logarithm are considered.

[0007] Piecewise-approximate logarithmic amplifiers may be subdivided into those that operate in a 'true' mode (also

called 'baseband' or 'video'), or a demodulating mode, or those that may operate in both modes. Demodulating logarithmic amplifiers provide the logarithm of the envelope of the input signal, as opposed to the logarithm of the entire signal provided by true logarithmic amplifiers. The present invention is primarily concerned with improving logarithmic amplifiers operating in the true mode, and so the demodulating ability of logarithmic amplifiers will not be discussed further here.

[0008] A progressive-compression logarithmic amplifier 20 is shown in FIG. 2. The signal path includes serially coupled amplifiers 204, with the output voltage of each amplifier coupled to a limiting transconductance element 206. The unamplified input signal is coupled to limiting transconductance element 206A that has a higher gain than elements 206. FIG. 3 parts (a) and (b) show the input-output characteristic of transconductance elements 206 and 206A respectively. A current bus 208 sums the output currents of all such elements to provide a system output current that is logarithmically related to the input signal 202. Typically the current bus is terminated by a resistive element 210 to provide an output voltage 212. Since the currents are summed in parallel, amplifier 20 belongs to the class of parallel summation logarithmic amplifiers.

[0009] In the progressive-compression amplifier in FIG. 2, relatively small input signals are simply amplified, whereas larger signals will cause the transconductance elements in each path to limit, starting with the last path and progressing toward the first path. FIG. 4 shows the DC response 402 of amplifier 20, where the transfer function of a four-path progressive-compression amplifier is shown. The amplifier response approximates a straight line in FIG. 4 because it is plotted on a semi-logarithmic axis. In order to reduce the error between the cusps of the approximation, more stages with smaller gains must be cascaded.

[0010] Progressive-compression amplifiers take advantage of multiple cascaded amplifiers to provide high gain. High gain directly translates into high dynamic range, because the logarithmic dynamic range extends from the point where the gain is highest to where the gain compresses to zero. In addition, progressive-compression amplifiers are easy to design since all of the cascaded stages are the same or similar. They also exhibit high tolerance to manufacturing process and temperature variations since these factors are likely to effect the gain of amplifiers 204 equally, which will simply shift or scale the logarithmic response without significantly distorting its logarithmic characteristics.

[0011] A limit on the frequency range of the progressive-compression amplifier may be seen by considering that the component amplifiers 204 each have finite bandwidth. If a single pole dominates the frequency response of these amplifiers, then the phase response of each amplifier will be close to -45 degrees near the pole frequency. The input signal 202 in FIG. 2 will pass through element 206A to the current bus with little phase shift, and this signal must be added in parallel with the output of the last serially-coupled amplifier 204 which will have significant phase shift from having passed through several amplifiers. Hence, if out-of-phase addition is to be avoided, either the amplifier must be operated well below its frequency limit, or the signals with little phase delay must have phase delay added to them prior to summation.

[0012] Another type of serially coupled logarithmic converter that exhibits better internal phase matching is the series linear-limit logarithmic amplifier 50 shown in FIG. 5, also known as the twin-gain stage logarithmic amplifier from A. Woroncow and J. Croney, "A True I.F. Logarithmic Amplifier using Twin-Gain Stages", The Radio and Electronic Engineer, September 1966, pp. 149-155. A number of identical stages 508 consisting of a limiting amplifier 506 in parallel with a buffering network 502 are cascaded. An input signal 504 that is relatively small will simply be amplified by all stages, while larger signals will cause the limiting amplifiers 506 to limit, starting with the last stage and progressing toward the input. The DC transfer function 404 of a logarithmic amplifier with three twin-gain stages is shown in FIG. 4. It may be seen that the response of the twin-gain stage amplifier is similar to that of the progressive-compression amplifier except beyond point 406. Point 406 approximately indicates the highest power levels handled by the logarithmic amplifier. Correct operation of the twin-gain stage amplifier requires that all of the buffering amplifiers 502 continue to pass the signal up to the input voltage indicated by point 406. The effect of this requirement on the bandwidth of the twin-gain stage 508 may be shown using the schematic diagram of one of the twin-gain stages in FIG. 6.

[0013] FIG. 6 shows two parallel differential-pair amplifiers in bipolar integrated circuit technology with shared collector resistance 602. The high-gain limiting amplifier includes transistors 606 and the low gain buffering amplifier includes transistors 604 and resistors 608 which are required to set the gain of the buffer amplifier. Referring to FIG. 5, it is required that the buffer amplifier 502 in the last stage continue to pass the signal, even after the amplifiers 506 in all previous stages limit and contribute a voltage  $V_L$ . The signal passed through the buffering amplifier in the last stage is thus equal to  $(N-1)V_L$ . In the schematic diagram in FIG. 6, the value  $V_L$  is equal to the product of  $I_{high}$  (at 612) and  $R_c$ . The limiting value of the buffering amplifier, equal to the product of  $I_{low}$  (at 610) and  $R_c$ , must be at least  $N-1$  times higher than  $V_L$ . For this reason,  $I_{low}$  must be at least  $N-1$  times higher than  $I_{high}$ . However,  $I_{high}$  is relatively high in order to achieve the required gain, so  $I_{low}$  will be quite high, requiring the use of large, high power devices with high parasitic capacitance. This capacitance will load the high gain stage and lower its bandwidth. One way to ease the output voltage swing requirements on the buffer amplifier is to lower its gain below unity, so that more input power is required in order for it to limit. However, the buffer amplifiers will still have some parasitic capacitance associated with them and this capacitance will still load the high gain amplifier in parallel and lower the bandwidth of the twin-gain stage.

[0014] Parallel amplification logarithmic converters overcome problems with internal delay matching and buffering requirements at the cost of decreased logarithmic dynamic range. FIG. 7 shows a parallel logarithmic amplifier 70. The amplifier consists of a single input coupled to a number of parallel voltage amplifiers 702A-N with gains as indicated. The output of each parallel amplifier is limited to the voltage range  $\pm V_L$  by limiters 704. Since the outputs of the limiters 704 are summed at 706 in parallel just as in amplifier 20, amplifier 70 also belongs to the class of parallel summation logarithmic amplifiers. The gains of the parallel amplifiers 702 may be uniformly scaled by an arbitrary

factor, which may reduce the gain of some paths below unity so that attenuators are used in place of amplifiers. The use of attenuators is undesirable in many applications though, since it increases the required input voltage needed to saturate the limiters 704 or requires limiters with lower corner voltages for a given drive power at the logarithmic amplifier input. As well, a large amount of attenuation increases the noise figure of the converter significantly.

[0015] Although parallel amplification logarithmic converters exhibit internal delay matching and low group delay distortion overall, they have distinct disadvantages. Since the parallel amplifiers have significantly different gains, it is more difficult than with serially coupled structures to achieve a logarithmic response that is highly tolerant of process variation. In addition, the parallel architecture is at a disadvantage in high-dynamic range applications since it does not exploit the high gain offered by cascaded amplifier structures.

[0016] What is needed is a logarithmic amplifier that attains relatively high gain, bandwidth, and efficiency; and internally matched phase and group delay, all with high tolerance to process variation.

#### SUMMARY OF THE INVENTION

[0017] Accordingly, it is one object of the present invention to provide a logarithmic amplifier with matched group delay amongst its internal paths.

[0018] It is another object of the invention to provide a logarithmic amplifier with high bandwidth.

[0019] Still another object of the invention is to provide a logarithmic amplifier with high dynamic range.

[0020] A further object of the invention is to provide a logarithmic amplifier that occupies little area when fabricated on an integrated circuit.

[0021] A still further object of the invention is to provide a logarithmic amplifier with low power consumption.

[0022] A still further object of the invention is to provide a logarithmic amplifier with high tolerance to process and temperature variation.

[0023] A still further object of the invention is to provide a low-noise logarithmic amplifier.

[0024] Therefore according to a first aspect of the invention, there is provided a piecewise-approximate logarithmic amplifier. In one embodiment, the amplifier has of a number of different amplification paths, called the gain section, with a summing/limiting circuit that provides the logarithmic output. The highest gain path consists of a cascade of  $N$  high gain amplifiers, where  $N$  is an integer greater than one. In a further aspect of the invention, there are at least  $N+2$  amplification paths, and these paths share amplifiers as much as possible. The output of each path passes through a circuit that limits the output signal at a certain level, with the limiting level for each path being preferably the same except the limiting level for the lowest gain path, which may be higher. After being limited, the path outputs are summed to form the logarithmic output.

[0025] The gains of all paths may be chosen using a unique design procedure, wherein it is shown that these gains result in an exact logarithmic relationship at fixed

points on the characteristic between the logarithmic amplifier's input and output signals.

[0026] A means is provided for designing the group and phase delay of each path in parallel summation logarithmic amplifiers to be nearly the same. One preferred delay method involves the use of delay amplifiers where the delay is set using capacitive elements. This delay method is used in the novel branch logarithmic amplifier described above, and may also be used to equalize the delay of the signals in a progressive-compression logarithmic amplifier.

[0027] The novel idea of using parallel feedback amplifiers (PFAs) as a building block in logarithmic amplifiers is described. PFAs are linear amplifiers that may be designed to have significantly different gains but similar phase characteristics. Hence, if these amplifiers are used as the logarithmic amplifier building block, then delay tuning may be accomplished using only the parasitic capacitances inherent in transistors. PFAs also have a higher bandwidth than standard differential pairs. However, since PFAs are very similar to differential pairs, then they may be used in place of differential pairs in both parallel summation logarithmic amplifiers and in the series linear-limit logarithmic amplifier.

[0028] The preferred embodiment of the logarithmic amplifier is DC coupled and uses fully balanced differential-pair amplifiers. Some optional circuits for reducing DC offsets are described. These circuits may be placed in negative feedback around the high-gain components of the logarithmic amplifier, and may be switched on or off.

[0029] The branch logarithmic amplifier and a matched delay progressive-compression amplifier have extremely high bandwidth and low group delay distortion. Accordingly, one application of these structures is in the single-sideband optical modulator shown in FIG. 1.

[0030] These and other aspects of the invention are described in the detailed description of the invention and claimed in the claims that follow.

#### BRIEF DESCRIPTION OF THE DRAWINGS

[0031] There will now be described preferred embodiments of the invention, with reference to the drawings, by way of illustration only and not with the intention of limiting the scope of the invention, in which like numerals denote like elements and in which:

[0032] FIG. 1 is a block diagram of an optical modulation system;

[0033] FIG. 2 is a block diagram of a progressive-compression amplifier;

[0034] FIG. 3 shows limiting transconductance element responses;

[0035] FIG. 4 shows DC logarithmic amplifier responses;

[0036] FIG. 5 is a block diagram of a twin-gain stage logarithmic amplifier;

[0037] FIG. 6 is a schematic diagram of one twin-gain stage;

[0038] FIG. 7 is a block diagram of a parallel logarithmic converter;

[0039] FIG. 8 is a simplified block diagram of one two-stage preferred embodiment;

[0040] FIG. 9 is a simplified block diagram of one three-stage preferred embodiment;

[0041] FIG. 10 is a simplified block diagram of one four-stage preferred embodiment;

[0042] FIG. 11 shows the transfer function of transconductance elements;

[0043] FIG. 12 is a simplified block diagram of a parallel-summation logarithmic amplifier;

[0044] FIG. 13 shows an ideal logarithmic amplifier response;

[0045] FIG. 14 is a simplified block diagram of an alternate two-stage preferred embodiment;

[0046] FIG. 15 shows the proposed delay amplifier used in a novel progressive-compression structure.;

[0047] FIG. 16 is a schematic of the input impedance matching circuit;

[0048] FIG. 17 is a schematic of an amplifier;

[0049] FIG. 18 is a schematic of the summer/limiter circuit;

[0050] FIG. 19 is a schematic diagram of a parallel feedback amplifier;

[0051] FIG. 20 is a schematic of a preferred embodiment of an amplifier to be used as negative feedback to reduce DC offsets; and

[0052] FIG. 21 is a schematic of one twin-gain stage parallel feedback amplifier embodiment.

#### DETAILED DESCRIPTION OF PREFERRED EMBODIMENTS

[0053] In this patent document, the word "comprising" is used in its non-limiting sense to mean that items following the word in the sentence are included and that items not specifically mentioned are not excluded. The use of the indefinite article "a" in the claims before an element means that one of the elements is specified, but does not specifically exclude others of the elements being present, unless the context clearly requires that there be one and only one of the elements.

[0054] FIG. 8 shows a two-stage example of the preferred embodiment. For simplicity, only one line is shown connecting each block, although all circuitry may use a pair of differential signals. The input impedance of the logarithmic amplifier is set to 50 Ohms using circuit 802. The noise figure of the overall logarithmic amplifier will be dominated by the noise performance of blocks 802, optional block 804 if it is included, and the first high gain amplifier 806. Low noise design recommendations will be given for these blocks as their schematic diagrams are shown. The highest gain path consists of amplifiers 806, and the lowest gain path is through amplifiers 808. The amplifier gains are chosen to provide a logarithmic transfer function for the overall structure, as will be shown in the preferred novel design procedure given later in this section.

[0055] The gains of the highest and lowest gain paths are preferably made as far apart as possible in order to maximize the logarithmic dynamic range. Breaking down the high gain path into a cascade of amplifiers offers an improvement in bandwidth over a single amplifier with the same gain. However, unlike other logarithmic amplifier topologies, preferably only the minimum number of amplifiers required to achieve the desired gain-bandwidth is used, which simplifies the task of simulating the group delay of the high-gain path in the other paths. The DC transfer function of amplifier **80** is shown by curve **408** in **FIG. 4**.

[0056] The two intermediate paths include amplifiers **812** and **810**. Since some amplifiers are shared, chip area and power are conserved. In addition, since some paths share a common preamplifier, any process or temperature variations in the shared amplifiers in these paths will affect all succeeding paths equally, providing some tolerance of logarithmic linearity to such effects.

[0057] Transconductance elements **814** convert amplifier output voltages to currents up to a maximum output current of  $+I_L$  after which point the output current limits. For improved precision, limiter **814A** on the lowest gain path has a larger limiting current such as  $+I_L A/(A-1)$  as will be shown. The output currents sum on current bus **818**, which is terminated by resistance **820** to form the logarithmic output voltage **816**. The value of resistor **820** may be 50 Ohms, so that the output impedance of the amplifier is matched to common microwave systems. There is some flexibility in the construction of transconductance elements **814**. Their transfer function is shown in **FIG. 11**, where the solid line **1102** indicates a perfect, symmetrical limiter and the dashed line **1104** shows a more practical hyperbolic tangent limiter. The positive and negative limiting currents of the limiters need not be the same.

[0058] In applications where increased logarithmic range is wanted, higher order structures such as those shown in **FIGS. 9** and **10** are the best choice. Any number of additional intermediate paths may be added, allowing for decreased logarithmic approximation error.

[0059] The highest gain path in all of the realizations will have the highest group and phase delay. In order to make the delay through the other paths the same as for this path, a means is provided for delaying the output of the lower gain paths. The method may consist of adding buffering amplifiers, which may be capacitively loaded to increase their delay. This method is used in amplifiers **80** (using capacitive delay elements **822**, **824** and **826**), **90** (using capacitive delay elements **910-922**), and **1000** (using capacitive delay elements **1012-1024** and **1030**) in **FIGS. 8**, **9**, and **10** respectively. The values of the capacitors are best determined through a simulation of delay in the different paths. However, the following observation is made about the capacitor values. In **FIG. 10**, the capacitor **1018** loading amplifier **1008** is labeled differently and is meant to be smaller than capacitors **1020** connected to the two buffer stages **808** that follow it. This is because the dominant pole limiting the frequency response of amplifier **1008** is assumed to be at a lower frequency than the pole of the buffering amplifiers **808** because the pole frequency is lower for a higher gain amplifier. Capacitive loading of an amplifier lowers the frequency of this pole, and so lowers the 3 dB bandwidth, and increases the group and phase delay. It is

more efficient in terms of maximizing bandwidth to lower the frequency of the pole in each amplifier to roughly the same point, than to lower any one amplifier's pole significantly more than the other amplifiers in that path.

[0060] In some branches there are more amplifiers than what is strictly needed to achieve the desired gain. For instance, amplifier **810** in **FIG. 8** is in the second lowest gain path but it shares the delay of the first amplifier **808** in the lowest gain path. This leads to reduced chip area and power consumption. In contrast, amplifier **810** in **FIG. 9** contains all of the gain required for that path, and is followed by two unity-gain buffers. Placing all of the gain as early as possible in a given path offers noise advantages. In **FIG. 9**, the gain in the highest gain path is shared between three serially coupled amplifiers **902**, while the gain in the next to highest gain path is shared between two of the amplifiers **902** and amplifier **904** connected in series. The gain in the intermediate gain path with gain of  $A(A-1)$  is shared between amplifier **906** and the first amplifier **902** of the highest gain path. The output of the gain paths is summed at current bus **908**.

[0061] Yet a third alternative, shown in **FIG. 10**, is to limit and sum the outputs of the two lowest gain paths after the first amplifier and then to buffer the summed signal through amplifiers **1028**. This method also saves power and chip area, but inherently reduces the bandwidth of the low gain path since the signal handling capability of buffering amplifier **1028** must be twice that of amplifier **808**, because two signals are being buffered. The exact arrangement of low gain amplifiers used should be chosen based on which requirements are the most stringent. In **FIG. 10**, the gain in the highest gain path is shared between four serially connected amplifiers **1002**, while the gain in the next to highest gain path is shared between three of the amplifiers **1002** and the amplifier **1004**, and so on for the gain paths including amplifiers **1006** and amplifier **1008**. The gain in the intermediate gain path with gain of  $A(A-1)$  is shared between amplifier **1008** and the first amplifier **1002** of the highest gain path. The output of the gain paths is summed on summing bus **1010**. The two lowest gain paths of **FIG. 10** uses the amplifier **810** with buffer amplifier **808** and limiters **814**, **814A** from **FIG. 8**, along with buffer amplifiers **1028** and transconductance element **1032**.

[0062] Having described preferred embodiments of the invention, the novel design procedure behind their creation is now given. Considering the parallel-summation logarithmic amplifier **1200** in **FIG. 12**, the desired transfer function of this circuit is shown in **FIG. 13**. Define the constant  $A$  as the factor increase in the input voltage between the cusps of the logarithmic approximation. The dynamic range of the logarithmic amplifier will be an  $A^N$  change in the input voltage  $V_{in}$ , so for a dynamic range  $D$  the constant  $A$  is chosen as  $D^{1/N}$ . As the input voltage increases, the gain decreases and follows the series

$$\begin{aligned} G_N &= g_m A^{N-1} \\ G_{N-1} &= g_m A^{N-2} \\ &\dots \\ G_k &= g_m A^{k-1} \end{aligned} \quad (1)$$

-continued

...

$$G_1 = g_m.$$

[0063] Using this knowledge of how the gain of the overall parallel-summation amplifier behaves, we can determine the gains of each path in amplifier **1200**.

[0064] Each line in equation (1) corresponds to the states where  $N, N-1, \dots, 1$  paths in amplifier **1200** are contributing linearly to the output current (a path ceases to contribute linearly once its output current limits). Hence, the gains of the overall structure in (1) are broken down as

$$G_1 = G_{p1} \quad (2)$$

$$G_2 = G_{p1} + G_{p2}$$

...

$$G_k = G_{p1} + G_{p2} + \dots + G_{pk}$$

...

$$G_N = G_{p1} + G_{p2} + G_{p3} + \dots + G_{pN}.$$

[0065] Solving (1) and (2) yields the gains of the paths through the parallel-summation amplifier **1200**

$$G_{p1} = g_m \quad (3)$$

$$G_{p2} = g_m(A-1)$$

$$G_{p3} = g_m A^2(A-1)$$

...

$$G_{pk} = g_m A^{k-2}(A-1)$$

...

$$G_{pN} = g_m A^{N-2}(A-1).$$

[0066] Having chosen the path gains, it may now be shown that  $I_{out}$  is logarithmically related to  $V_{in}$ . Assuming that the  $k_{th}$  path in amplifier **1200** is just on the point of limiting, then the input is

$$V_{in_m} = V_{in} = \frac{I_L}{G_{pk}} \quad (4)$$

[0067] where  $I_L$  is the limiting current of the  $k_{th}$  path.

[0068] However,  $G_{pk}$  is known from (3) to be  $G_{pk} = g_m A^{k-2}(A-1)$  for  $k \geq 2$ , so that

$$V_{in} = \frac{I_L}{g_m A^{k-2}(A-1)} \quad k \geq 2. \quad (5)$$

[0069] Additionally, if the  $k_{th}$  path is limiting, then there are  $N-k$  paths with higher gains that are already limiting, and  $k-1$  more paths that are still amplifying linearly. Thus, the output current is

$$I_{out} = (N-k)I_L + [G_{p1} + G_{p2} + \dots + G_{pk}]V_{in}. \quad (6)$$

[0070] Using (1) and (2),

$$G_k = G_{p1} + G_{p2} + \dots + G_{pk} \quad (7)$$

$$= g_m A^{k-1}.$$

[0071] Using (5) and (7), (6) may be written as

$$I_{out} = (N-k)I_L + \frac{AI_L}{A-1}. \quad (8)$$

[0072] Additionally, (5) is rewritten as

$$k = \log_A \left( \frac{A^2 I_L}{V_{in} g_m (A-1)} \right) \quad (9)$$

[0073] Finally, substituting (9) into (8) gives

$$I_{out} = I_L \left( N + \frac{A}{A-1} + \log_A \left( \frac{V_{in} g_m (A-1)}{A^2 I_L} \right) \right) \quad (10)$$

[0074] which is the desired logarithmic relationship between  $I_{out}$  and  $V_{in}$ .

[0075] There is one final consideration regarding the case of  $k=1$ , not considered in (5), which is the case where the lowest gain path limits. When path  $G_{p2}$ , whose gain is  $G_{p2} = g_m(A-1)$ , limits and provides a current of  $I_L$ , the input voltage is

$$V_{in} = \frac{I_L}{G_{p2}} = \frac{I_L}{g_m(A-1)}. \quad (11)$$

[0076] At this input voltage, the current provided by the lowest gain path is

$$I = g_m V_{in} = \frac{g_m I_L}{g_m(A-1)} = \frac{I_L}{A-1}. \quad (12)$$

[0077] This point occurs at the total system output current of  $(N-1)I_L + C$  in **FIG. 13**, and in order for the logarithmic slope of the output to continue, the lowest gain path must provide another  $I_L$  of current before it limits. Adding this to (12) gives

$$I_{L1} = \frac{I_L}{A-1} + I_L = \frac{A}{A-1} I_L. \quad (13)$$

[0078] which represents the limiting current level of the lowest gain path. Thus, the lowest gain path provides a maximum current that is  $A/(A-1)$  times higher than the other paths.

[0079] Having derived the ideal path gains for a parallel-summation logarithmic amplifier, some useful variations from the ideal are now described. FIG. 14 shows an alternate preferred embodiment of the present invention that uses path gains of 1 (using buffer amplifiers 808),  $A^3$  (using one of the buffer amplifiers 808 and amplifier 1406),  $A^2$  (using amplifiers 1402 and 1404), and  $A^3$  (using amplifiers 1402) all summed on current bus 1410. Capacitors 1408, 1412, and 1414 are used to equalize the path delays. Using these path gains has the advantage of simplicity, although the cusps of the logarithmic approximation in FIG. 4 will no longer lie on a logarithmic line but merely close to one. Furthermore, it should be noted that if the path gains were chosen to follow the  $1, A^2, A^3, \dots, A^N$  pattern, then some of the component amplifiers within the intermediate gain paths in FIGS. 9 and 10 would branch at different points.

[0080] Also included in the embodiment of the present invention in FIG. 14 is that the limiters at the output of each path are the same. Such a choice has the advantage of simplicity, although leads to a somewhat less accurate response.

[0081] The delay amplifiers presented so far, which use capacitive elements to set their delay, may be used in the novel configuration 1500 shown in FIG. 15 to improve the internal delay matching of the progressive-compression amplifier. In amplifier 1500, the highest gain path is formed from three series connected amplifiers 1504 with limiter 814, and the next to highest gain path is formed from the first two amplifiers 1504 and delay amplifier 808 (capacitively loaded by capacitor 1508) with limiter 814. Delay amplifiers 808, capacitively loaded at 1506 and 1508, are added to some paths in the amplifier so that the phasing and group delay through each path is the same. However, rather than delaying all paths separately, the signals in the two lowest gain paths are limited by elements 814A and 814 and then summed across resistor 1510. The combined signal across resistor 1510 is then delayed through a single path consisting of delay amplifier 1028, capacitively loaded at 1512, and transconductance element 1032 before being added to the signals from the higher gain paths to form the output signal 1514. The output signal 1514 will be logarithmically related to the input signal 1502. Combining the delay paths reduces the amount of delay hardware needed compared to the case where the paths are delayed separately.

[0082] Having shown the block diagrams of the present invention, the schematic diagrams of the components of the preferred embodiments are now described. FIG. 16 is the schematic diagram of the impedance matching circuit 802. Bipolar transistors 1602 are arranged in emitter-follower configuration, with 50 Ohm resistors 1604 connected from base to collector. Transistors 1606 and 1618 and resistors 1608, 1610, 1614, and 1616 form a current source that

supplies power to the emitter followers. Capacitor 1612 is useful for reducing the output noise of this circuit. The circuit in FIG. 16 will be one of the most important circuits in the logarithmic amplifier in terms of noise performance. For this reason, transistors 1602 should be made relatively large in order to minimize the thermal noise from their parasitic base resistance. The designer should also monitor the amount of shot noise contributed by the collector current of transistors 1602, and try to minimize this noise either with the help of CAD design tools or using low noise circuit design techniques.

[0083] FIG. 17 is a schematic diagram of the amplifiers used for both amplification and delay. The four transistors 1712 may be used to amplify the signal, with the gain given approximately by

$$\frac{V_{out}}{V_{in}} \cong \frac{g_m R_c}{(1 + g_m R_e)} \quad (14)$$

[0084] where  $g_m$  is the transconductance of the transistors 1712. If a gain of less than one is desired, then this may be accomplished by making  $R_e$  (1714) larger than  $R_c$  (1704) or by using a low bias current. Resistors 1706, 1708, 1716, 1720, and 1728 and transistors 1718, 1722, and 1730 are used to help bias amplifier 1700. Resistors 1726 and 1732 and capacitor 1724 are useful for reducing the output noise of this circuit. Capacitors 1702 may be used for increasing the group delay and phase shift of amplifier 1700. Antiphase signals at nodes 1734A and 1734B pass through transistors 1710 in order to reduce the DC voltage level of the output signal to a convenient level. The shape of the transfer function of this amplifier is a hyperbolic tangent, the same as the dotted line 1104 in FIG. 11 except that here the output variable is voltage, not current.

[0085] If amplifier 1700 is used as the first high gain amplifier at the input of the logarithmic amplifier, such as amplifier 804 or 806 in FIG. 8, then it will be a very important circuit in terms of the noise performance of the logarithmic amplifier. In this case, resistors 1714 should be omitted, as they will contribute significant thermal noise. Furthermore, transistors 1712 should be made relatively large in order to minimize thermal noise arising from their parasitic base resistance.

[0086] FIG. 18 shows a four-stage summing and limiting circuit. This circuit implements, from FIG. 8, three limiters 814, one limiter 814A, current bus 818, and termination element 820. Element 820 at the top of the schematic is chosen as 50 Ohms to allow for efficient connection to microwave systems. There are four pairs of transistors 1816, and each pair accepts one differential input signal, for example between 1804A and 1804B. When the input signal applied to a pair of transistors 1816 swings positive and negative, the constant current supplied to that transistor pair from transistors 1818 or 1820 is steered from one side of the pair to the other. However, for large input signals, all of the available current shifts to the side with the highest positive applied voltage. When all of the available current flows through one side of a pair of transistors 1816, the current is said to be limited. This provides the limiting action required at the output of each path in the logarithmic amplifier. The pair of transistors 1816 that accept the inputs 1804 A and B

comprises the lowest gain path and is biased with a higher constant current by transistor **1818** than the other pairs, which are supplied by transistors **1820**. This means that this part of the summer has a higher limiting value and a higher gain than what is used for the other three input pairs composed of inputs **1806-1810**. The higher gain will raise the gain of the lowest gain path above unity, however the gain of the buffer amplifiers in this path may be lowered to compensate. All of the currents flowing through transistors **1816** flow through isolation transistors **1802** and through output resistances **820**. The voltages across resistances **820** form the complementary output voltage pair, which will be logarithmically related to the input of the overall logarithmic amplifier if the gains of the paths are chosen appropriately. Resistors **1812**, **1814**, **1822**, **1824**, **1832** and transistor **1826** are used to help bias amplifier **1800**. Resistors **1830** and **1834** and capacitor **1828** are used to reduce the output noise of amplifier **1800**.

[0087] It should be cautioned that when DC-coupled amplifiers are used, the gain of amplifier **1800** should not be made too large. This is because a high-gain summing circuit will only further amplify DC offset errors. For this reason, it may be desirable in some cases to use the well known technique of resistive emitter degeneration to lower the summer gain, which involves placing resistors in series with the emitter leads of transistors **1816**. However, the gain of the summing amplifier should also not be made too low, or a larger signal will be required in order to steer all of the branch currents to one side of the amplifier.

[0088] FIG. 19 shows an alternate circuit **1900** that may be used for both amplification and delay in place of amplifier **1700**. This circuit is a parallel feedback amplifier (PFA), and it is described in Y. M. Greshishchev and P. Schvan, "A 60-dB Gain, 55-dB Dynamic Range, 10-Gb/s Broad-Band SiGe HBT Limiting Amplifier", IEEE Journal of Solid State Circuits, volume 34, number 12, pp. 1914-1920, December 1999. What is novel here is the use of a PFA in a piecewise-approximate logarithmic amplifier. The PFA is a useful building block not only for its high bandwidth, but also because of its superior delay characteristics.

[0089] The low frequency gain of amplifier **1900** is approximately given by

$$\frac{V_{out}}{V_{in}} = G \cong \frac{g_{m1}(R_f + r_{d1})(R_1 + R_2)}{(1 + g_{m1}R_e)(R_1 + r_{d5})} \quad (15)$$

[0090] where  $g_{m1}$  is the transconductance of transistors Q1 and Q2 (**1918**) and Q3 and Q4 (**1902**);  $r_{d1}$  is equal to  $1/g_{m1}$ , and similarly  $r_{d5}$  is the inverse of the transconductance of transistors Q5 and Q6. By adjusting the relative value of resistors **1904** and **1910** in relation to the values of resistors **1912**, amplifiers of significantly different gains but of similar delay characteristics may be realized. This is extremely advantageous, because this means that delay capacitors **1702** are not required when the PFA is used as the logarithmic amplifier building block. However, when amplifier **1900** is used only for delay, emitter degeneration resistors **1920** may be useful for lowering the gain. If resistors **1920** are not used, resistors **1912** and **1932** should be made from the same material so that the effect of their changes with temperature and process on the amplifier gain cancel.

Resistors **1936** and **1942** and capacitor **1926** are used to help reduce the output noise of this circuit. Transistors **1938** and **1940** form an emitter follower impedance conversion stage.

[0091] Amplifier **1900** has some other important features to allow for stable operation despite variations in manufacturing and temperature. Transistors **1924**, **1928**, **1930**, and **1934** form a DC current source. This scheme may be used in place of the biasing schemes shown in FIG. 16, 17, and 18. The collector current of transistors **1930** and **1934** increases with increasing temperature and so is PTAT (proportional to absolute temperature). If transistors **1930** and **1934** are made much larger than transistor **1928**, then the collector current of transistors **1930** and **1934** will increase more steeply with increasing temperature. As a separate effect, the transconductances of transistors **1918** and **1916** decrease with increasing temperature. These effects will roughly cancel each other in amplifier **1900**, creating an overall amplifier whose gain is substantially independent of temperature. Unfortunately, the value of resistor **1922** will vary with process variations. In implementations where increased precision is required, it will be necessary to replace the DC current source that is shown with a current source that uses a bandgap reference voltage circuit. A description of these circuits may be found in textbooks on circuit design, such as Gray et al, "Analysis and Design of Analog Integrated Circuits", fourth edition, John Wiley & Sons Inc., 2001.

[0092] The design issue of controlling DC offset errors was raised in discussing the summing circuit **1800**. Offset voltages in DC coupled logarithmic amplifiers must be minimized through careful design since they may unbalance the amplifier and reduce the available signal range. FIG. 20 shows one DC offset reduction scheme that is amenable to fabrication in integrated circuit form. If amplifier **2000** is made to have a very high gain and small bandwidth compared to amplifier **1700** or **1900**, and if it is connected in negative feedback around amplifier **1700** or **1900**, then the effect will be to greatly reduce the DC offsets in the logarithmic amplifier. If amplifier **2000** is connected in negative feedback around amplifier **1700** or **1900**, then  $V_{out+}$  and  $V_{out-}$  in amplifier **1700** or **1900** should connect to terminals  $V_{in+}$  and  $V_{in-}$  in amplifier **2000** respectively. As well, terminals **1734A** and **1734B** in amplifier **2000** would connect to terminals **1734A** and **1734B** in amplifier **1700**, or to terminals **1914A** and **1914B** in amplifier **1900**. This scheme will not eliminate the DC offsets entirely, because amplifier **2000** will have its own DC offset associated with it. Still, it will reduce the output referred DC offset of amplifier **1700** or **1900** to the approximate level of the input referred DC offset of amplifier **2000**. If the impedance at the collector node of transistor **2010** is high, then the designer can use only modest values for capacitors **2012** to make the bandwidth of amplifier **2000** much less than that of amplifiers **1700** and **1900** so that the negative feedback does not cancel significant portions of useful bandwidth. Furthermore, the drain currents of MOSFET transistors **2006** can be relatively small, so that amplifier **2000** does not change the operating points of amplifiers **1700** or **1900** when it is connected to them. Furthermore, the entire feedback circuit can be easily switched on or off by connecting point **2014** to the circuit's positive or negative voltage supply respectively. Transistors **2002** and **2004** form the high impedance active load of amplifier **2000**. Transistors **2008** form a voltage level

shifting circuit and transistors **2016**, **2018**, **2020**, **2022**, and **2024** are used to supply power to amplifier **2000**.

[**0093**] So far, this detailed description has dealt with parallel summation logarithmic amplifiers. However, the idea of using amplifiers with feedback in a piecewise approximate logarithmic amplifier may be extended to the series linear-limit logarithmic amplifier in **FIG. 5**. If this were done, one of the twin gain stages in **FIG. 6** would become amplifier **2100** shown in **FIG. 21**. Amplifier **2100** contains two gain paths; a high gain path containing transistors **2114** and a low gain path containing transistors **2116** and resistors **Re (2118)**. Resistors **R1 (2104)**, **R2 (2106)**, and **Rf (2108)** are common to both paths. The gain of the high gain path is approximately given by

$$G_{high} \cong \frac{g_{m1}(R_f + r_{d5})(R_1 + R_2)}{(R_1 + r_{d7})} \quad (16)$$

[**0094**] where  $g_{m1}$  is the transconductance of transistors **Q1** and **Q4**,  $g_{m5}$  is the transconductance of transistors **Q5** and **Q6 (2102)**,  $r_{d5}$  is equal to  $1/g_{m5}$ , and similarly  $r_{d7}$  is the inverse of the transconductance of transistors **Q7** and **Q8 (2110)**. Using the same notation, the gain of the low gain path is approximately given by

$$G_{low} \cong \frac{g_{m2}(R_f + r_{d5})(R_1 + R_2)}{(1 + g_{m2}R_e)(R_1 + r_{d7})} \quad (17)$$

[**0095**] Using these equations, the component values in amplifier **2100** may be chosen to set  $G_{low}$  to a low gain, unity for instance, and  $G_{high}$  to the desired value. Furthermore, for a given  $I_{high}$  in **FIG. 21**,  $I_{low}$  should be made at least equal to  $N I_{high}$  where  $N$  is the number of twin-gain stages to be cascaded. Satisfying this condition ensures that the low gain path will not saturate prematurely. Another necessary condition to ensure that the low gain path does not saturate too easily is that **12** should be made sufficiently large. The requirement on  $I_2$  may be expressed by using the fact that the gain from the collector of **Q2** to the collector of **Q7** is  $g_{m7}(R_1 + R_2)$ . As well, the limiting value at the output of one side of the twin-gain stage is  $I_2(R_1 + R_2)$ . Using these values, the requirement on  $I_2$  becomes

$$I_2 \geq I_{low}(R_1 + r_{d5})g_{m7} \quad (18)$$

[**0096**] Hence, by careful design, amplifier **2100** may be designed to have a high and a low gain path, similar to the traditional twin-gain stage in **FIG. 6**. However, the amplifier **2100** can be made to have a significantly higher bandwidth due to the introduction of the parallel feedback technique. Resistors **2120**, **2134**, **2136**, **2138**, and transistors **2122**, **2126**, **2128**, **2130**, and **2132** form a PTAT current supply circuit. Transistors **2112** and **2140** form an emitter follower impedance conversion stage. Resistors **2142** and capacitor **2124** are useful for lowering the output noise of amplifier **2100**.

[**0097**] The amplifiers disclosed in this patent are suitable for use in the single-sideband optical modulator shown in **FIG. 1**. DC level shifters, delay elements and linear amplification components may be necessary both before and after

the logarithmic amplifier in order for the logarithmic amplifier to interface correctly with the Hilbert transformer **108** and the input signal **100**.

[**0098**] A person skilled in the art could make immaterial modifications to the invention described in this patent document without departing from the essence of the invention that is intended to be covered by the scope of the claims that follow.

What is claimed is:

1. A logarithmic amplifier, comprising:

a high gain section having plural gain paths, each gain path including an amplifier and a signal limiter in series, and each gain path being connected in parallel to a common input, each of the gain paths having an output and a gain;

the outputs of the plural gain paths being connected to a signal summation circuit and summed to form an output signal;

a low gain section connected between the common input and the signal summation circuit;

delay elements in plural gain paths of the high gain section and the low gain section, the delays of the delay elements being selected to compensate for variation between group and phase delay of the gain paths, the delay elements of at least two of the plural gain paths sharing a common amplifier; and

the gain of each of the plural gain paths and the low gain section being selected so that the output signal varies logarithmically with the input voltage.

2. The logarithmic amplifier of claim 1 in which each delay element comprises a buffer amplifier.

3. The logarithmic amplifier of claim 2 in which each buffer amplifier is capacitatively loaded for delay compensation.

4. The logarithmic amplifier of claim 1 in which the highest gain path in the high gain section comprises at least two series connected amplifiers.

5. The logarithmic amplifier of claim 4 in which the highest gain path in the high gain section shares an amplifier with the next highest gain path in the high gain section.

6. The logarithmic amplifier of claim 1 in which each gain path in the high gain section shares an amplifier with another gain path in the high gain section.

7. The logarithmic amplifier of claim 1 further comprising an amplifier on the common input to the high gain section and low gain section.

8. The logarithmic amplifier of claim 1 in which the gain paths share amplifiers such that the number of gain paths in the logarithmic amplifier exceeds the number of amplifiers in the highest gain path of the high gain section by at least two.

9. The logarithmic amplifier of claim 1 in which the gains of the gain paths are selected such that the ratio of succeeding gains in the gain paths is a function of  $A-1$  where  $A$  is equal to  $D^{1/N}$ ,  $D$  is the dynamic range of the logarithmic amplifier and  $N$  is the number of gain paths in the logarithmic amplifier.

10. The logarithmic amplifier of claim 1 in which the common input is connected to a source of an information signal.

11. The logarithmic amplifier of claim 10 in combination with a series connected Hilbert transformer to produce a control signal that is output to a phase modulator and combined with an envelope signal to produce a single sideband signal.

12. The logarithmic amplifier of claim 11 in which the envelope signal is carried on an optical carrier.

13. The logarithmic amplifier of claim 1 in which the low gain section has a gain path having a signal limiter with a larger limiting level than the limiting level of the signal limiters in the high gain section.

14. A logarithmic amplifier, comprising:

plural gain paths, one of the gain paths being a highest gain path and the highest gain path containing N amplifiers, where N is an integer greater than one, each gain path including an amplifier and a signal limiter in series, and each gain path being connected in parallel to a common input, each of the gain paths having an output and a gain;

the outputs of the plural gain paths being connected to a signal summation circuit and summed to form an output signal;

at least two of the gain paths sharing a common amplifier such that the logarithmic amplifier has at least N+2 gain paths;

a low gain section connected between the common input and the signal summation circuit; and

the gain of each of the plural gain paths and the low gain section being selected so that the output signal varies logarithmically with the input voltage.

15. The logarithmic amplifier of claim 14 in which the highest gain path in the high gain section comprises at least two series connected amplifiers.

16. The logarithmic amplifier of claim 15 in which the gain of the series connected amplifiers is distributed with higher gain closer to the common input.

17. The logarithmic amplifier of claim 14 in which the highest gain path in the high gain section shares an amplifier with the next highest gain path in the high gain section.

18. The logarithmic amplifier of claim 14 in which each gain path in the high gain section shares an amplifier with another gain path in the high gain section.

19. The logarithmic amplifier of claim 18 in which the minimum number of amplifiers is used by sharing of amplifiers in the high gain section to obtain a desired gain bandwidth product.

20. The logarithmic amplifier of claim 14 further comprising an amplifier on the common input to the high gain section and low gain section.

21. The logarithmic amplifier of claim 14 in which the gains of the gain paths are selected such that the ratio of succeeding gains in the gain paths is a function of A-1 where A is equal to  $D^{1/N}$ , D is the dynamic range of the logarithmic amplifier and N is the number of gain paths in the logarithmic amplifier.

22. The logarithmic amplifier of claim 14 in which the common input is connected to a source of an information signal.

23. The logarithmic amplifier of claim 22 in combination with a series connected Hilbert transformer to produce a

control signal that is output to a phase modulator and combined with an envelope signal to produce a single sideband signal.

24. The logarithmic amplifier of claim 23 in which the envelope signal is carried on an optical carrier.

25. The logarithmic amplifier of claim 14 in which the low gain section has a gain path having a signal limiter with a larger limiting level than the limiting levels of the signal limiters in the high gain section.

26. A logarithmic amplifier, comprising:

a high gain section having plural gain paths, each gain path including an amplifier and a signal limiter in series, and each gain path being connected in parallel to a common input, each of the gain paths having an output and a gain;

the outputs of the plural gain paths being connected to a signal summation circuit and summed to form an output signal;

the gains of the gain paths being selected such that the ratio of succeeding gains in the gain paths is a function of A-1 where A is equal to  $D^{1/N}$ , D is the dynamic range of the logarithmic amplifier and N is the number of gain paths in the logarithmic amplifier;

a low gain section connected between the common input and the signal summation circuit; and

the gain of each of the plural gain paths and the low gain section being selected so that the output signal varies logarithmically with the input voltage.

27. The logarithmic amplifier of claim 26 further comprising a delay element in plural gain paths of the high gain section and the low gain, the delays of the delay elements being selected to compensate for variation between group phase delay of the gain paths and each delay element comprising a buffer amplifier.

28. The logarithmic amplifier of claim 27 in which each buffer amplifier is capacitatively loaded for delay compensation.

29. The logarithmic amplifier of claim 26 in which the highest gain path in the high gain section comprises at least two series connected amplifiers.

30. The logarithmic amplifier of claim 29 in which the highest gain path in the high gain section shares an amplifier with the next highest gain path in the high gain section.

31. The logarithmic amplifier of claim 26 in which each gain path in the high gain section shares an amplifier with another gain path in the high gain section.

32. The logarithmic amplifier of claim 26 further comprising an amplifier on the common input to the high gain section and low gain section.

33. The logarithmic amplifier of claim 26 in which the gain paths share amplifiers such that the number of gain paths in the logarithmic amplifier exceeds the number of amplifiers in the highest gain path of the high gain section by at least two.

34. The logarithmic amplifier of claim 26 in which the common input is connected to a source of an information signal.

35. The logarithmic amplifier of claim 34 in combination with a series connected Hilbert transformer to produce a control signal that is output to a phase modulator and combined with an envelope signal to produce a single sideband signal.

**36.** The logarithmic amplifier of claim 35 in which the envelope signal is carried on an optical carrier.

**37.** The logarithmic amplifier of claim 26 in which the low gain section has a gain path having a signal limiter with a larger limiting signal than the limiting signals of the signal limiters in the high gain section.

**38.** A logarithmic amplifier, comprising:

a high gain section having plural gain paths, each gain path including an amplifier and a signal limiter in series, and each gain path being connected in parallel to a common input, each of the gain paths having an output and a gain;

the outputs of the plural gain paths being connected to a signal summation circuit and summed to form an output signal;

a low gain section connected between the common input and the signal summation circuit;

delay elements in plural gain paths of the high gain section and the low gain section, the delays of the delay elements being selected to compensate for variation between group and phase delay of the gain paths, each delay element comprising a capacitatively loaded amplifier; and

the gain of each of the plural gain paths and the low gain section being selected so that the output signal varies logarithmically with the input voltage.

**39.** A logarithmic amplifier, comprising:

plural limiting gain stages connected together, the plural limiting gain stages having an input for receiving an input signal, and being connected together to an output for producing an output signal, each limiting gain stage having a gain selected so that the output signal varies logarithmically with the input signal; and

each of the limiting gain stages incorporating a parallel feedback amplifier.

**40.** The logarithmic amplifier of claim 39 in which the plural limiting gain stages are cascaded together to form a serially coupled logarithmic amplifier.

**41.** The logarithmic amplifier of claim 40 in which each plural limiting gain stage comprises a limiting amplifier in parallel with a buffering network.

**42.** The logarithmic amplifier of claim 39 in which the plural limiting gain stages are connected in parallel to a common input and to a common summing output to form multiple parallel gain paths of a piece-wise approximate logarithmic amplifier.

**43.** The logarithmic amplifier of claim 42 in which the plural limiting gain stages each comprise at least one amplifier in series with a limiting amplifier.

**44.** The logarithmic amplifier of claim 43 in which at least two of the plural limiting gain stages share a common amplifier.

**45.** The logarithmic amplifier of claim 44 in which the plural limiting gain stages include a highest gain stage, and the highest gain stage incorporates at least two series connected amplifiers.

**46.** The logarithmic amplifier of claim 45 in which the highest gain stage shares a common amplifier with the next highest gain stage.

**47.** The logarithmic amplifier of claim 46 in which the gains of the gain stages are selected such that the ratio of succeeding gains in the gain stages is a function of  $A-1$  where  $A$  is equal to  $D^{1/N}$ ,  $D$  is the dynamic range of the logarithmic amplifier and  $N$  is the number of stages paths in the logarithmic amplifier.

**48.** The logarithmic amplifier of claim 39 in which the input is connected to a source of an information signal.

**49.** The logarithmic amplifier of claim 48 in combination with a series connected Hilbert transformer to produce a control signal that is output to a phase modulator and combined with an envelope signal to produce a single sideband signal.

**50.** The logarithmic amplifier of claim 49 in which the envelope signal is carried on an optical carrier.

\* \* \* \* \*